

TF30B-H



### Typical Applications

- Inkjet printer
- Fireplace
- Water purifier
- Analytical instruments
- Semi-conductors
- Medical equipment
- Lab equipment
- Food & beverage industry
- Cleaning industry

### Features

- Self priming function is available
- Dry running is acceptable
- Food grade type can be customized
- Excellent reliability
- Maintenance free
- Brushless DC motor
- Inside controller type
- The motor runs low vibration and quieter than brush motor
- Spark free
- Durable ideal lifetime 15,000 hours.

### Structure

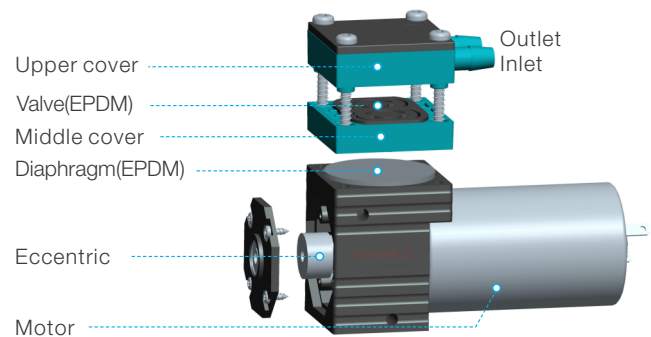

### Specification

Model	Pressure Pump (Item Number)	Vacuum Pump (Item Number)	Rated Voltage (VDC)	No Load Current (A)	Max Pressure (kPa)	Max Vacuum (kPa)	Max Flow (L/min)	Motor Type	Lifetime (Hours)
TF30B-H	TM30B-H12-P13004	TM30B-H12-V6504	12	0.2	130	-65	4.5	BLDC	10,000
	TM30B-H24-P13004	TM30B-H24-V6504	24	0.2	130	-65	4.5	BLDC	10,000

### Curve

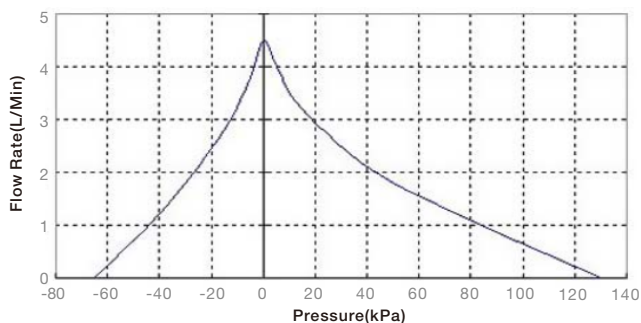

### Dimension (mm)

